

In order to use a GenFlex EPDM Pre-Molded Pipe Boot as a pourable sealer pocket follow these steps:

1. Cut the boot at the lowest ring.
2. Clean the deck membrane, the boot flange and the inside of the pipe boot with EPDM Cleaner, and allow to flash-off.
3. For Peel & Stick EPDM Pipe Boots apply EPDM Primer to the deck membrane and to the inside of the boot and allow to flash off. Peel the release liner from the boot flange and mate to the prepared deck membrane and roll with a 2" (51 mm) roller.
4. For molded EPDM Pipe Boots (non Peel & Stick) apply G-400 Splice Adhesive to the bottom of the boot flange and the deck membrane and allow to flash off before mating the flange to the prepared deck membrane.
5. Fill the pipe boot with GenFlex Pourable Sealer mounding the sealer to allow water to shed. Extend the sealer to cover the top edges of the boot.

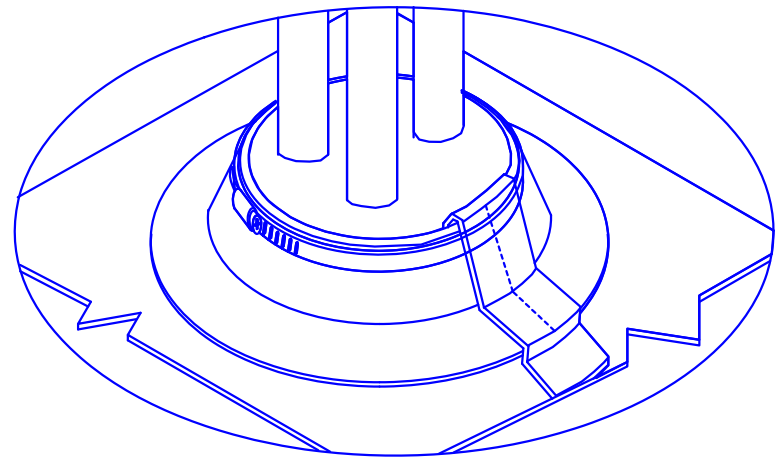

NOTE: In order to achieve an adequate seal, there must be 1" (25 mm) of space between penetrations and also between penetrations and the sides of the pre-molded pipe boot .

If the boot cannot be installed over the top of a penetration, the boot may be cut in order to place the boot around the object being sealed. If a cut is required, it must be overlaid with FlexFlash E and spliced back together prior to filling the boot with GenFlex Pourable Sealer. Ensure the strip-in flashing extends a minimum of 3" (76 mm) beyond the step-off of the flange to ensure an adequate seal.



EPDM Pre-Molded Pipe Boot as a Pourable Sealer Pocket	
EPDM Systems	ACCEPTABLE SYSTEMS: All Systems

MAXIMUM WARRANTY: 20 Years	
ISSUE / REVISION DATE: 6-24-2015	DETAIL NO. E-9.03
NOT TO SCALE	