

1.

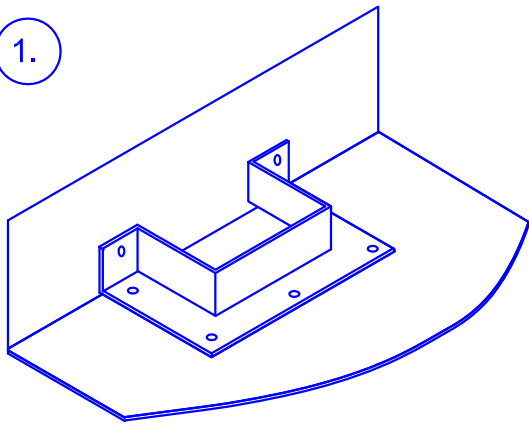

3-sided Pourable Sealer Pocket fabricated with 24 ga (0.61 mm) steel metal. Follow SMACNA Guidelines.

2.

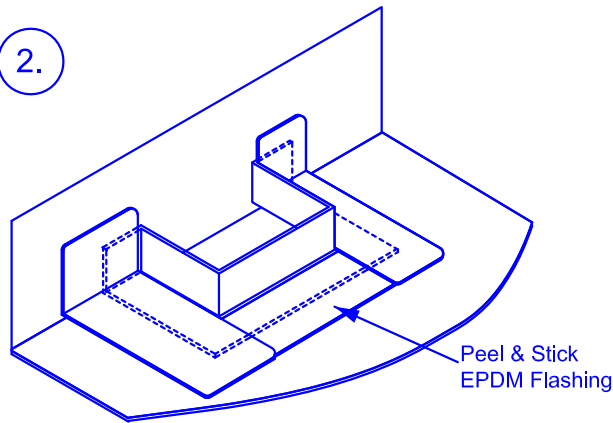

Strip in pocket flange with Peel & Stick EPDM Flashing.

3.

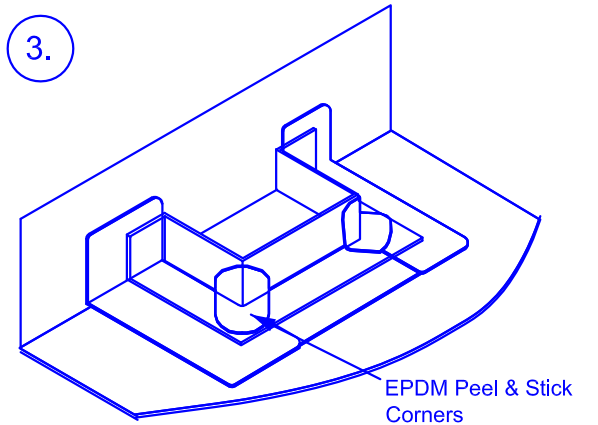

Apply EPDM molded corners to the pocket. (Required because of the need to fill out flange radius corners with a separate piece of coated metal)

4.

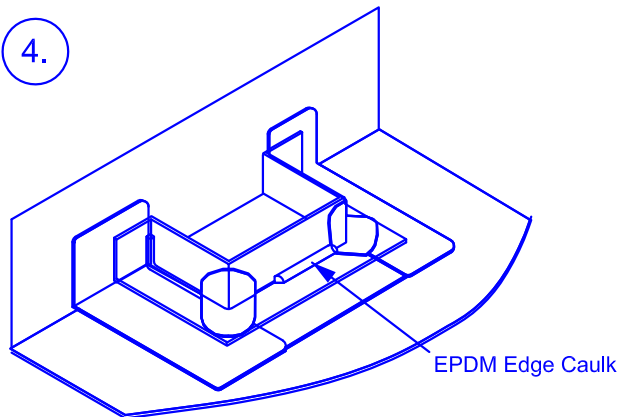

Apply EPDM Caulk to the flashing edge that rests next to the metal pan all the way around the detail to keep water from sitting in the void.

5.

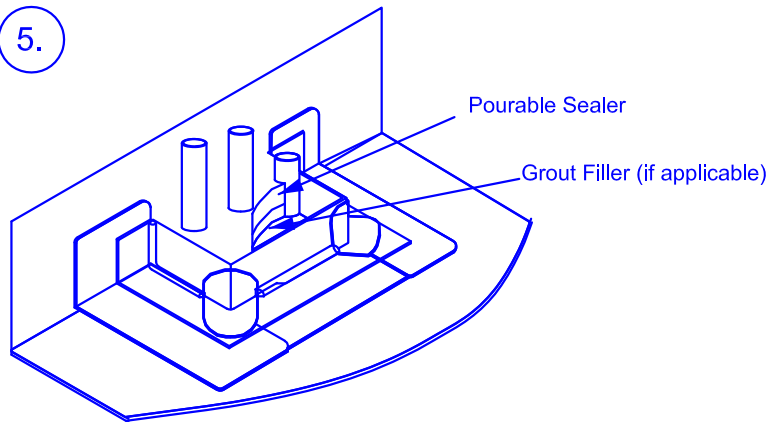

Penetrations must be positioned a minimum of 1" (25 mm) apart and also 1" (25 mm) from the pocket sides. Pourable Sealer must be a minimum of 2" (51 mm) deep - non-shrinking grout filler may be used to fill a pocket to a point 2" (51 mm) from top if the pocket exceeds 2" (51 mm) in depth.



Three-Sided Pourable Sealer Pocket

EPDM Systems

ACCEPTABLE SYSTEMS:
All Systems

MAXIMUM WARRANTY: **20 Years**

ISSUE / REVISION
DATE:
6-24-2015

NOT TO SCALE

DETAIL NO.

E-9.04