

The logo is set against a background of a globe with a red curved border at the top and bottom. The word "Firestone" is written in a large, red, stylized font with a slight shadow effect.

Firestone

BUILDING PRODUCTS

TPO

Membrane attachment
and
Base Tie-In

Firestone
BUILDING PRODUCTS

Adhered System

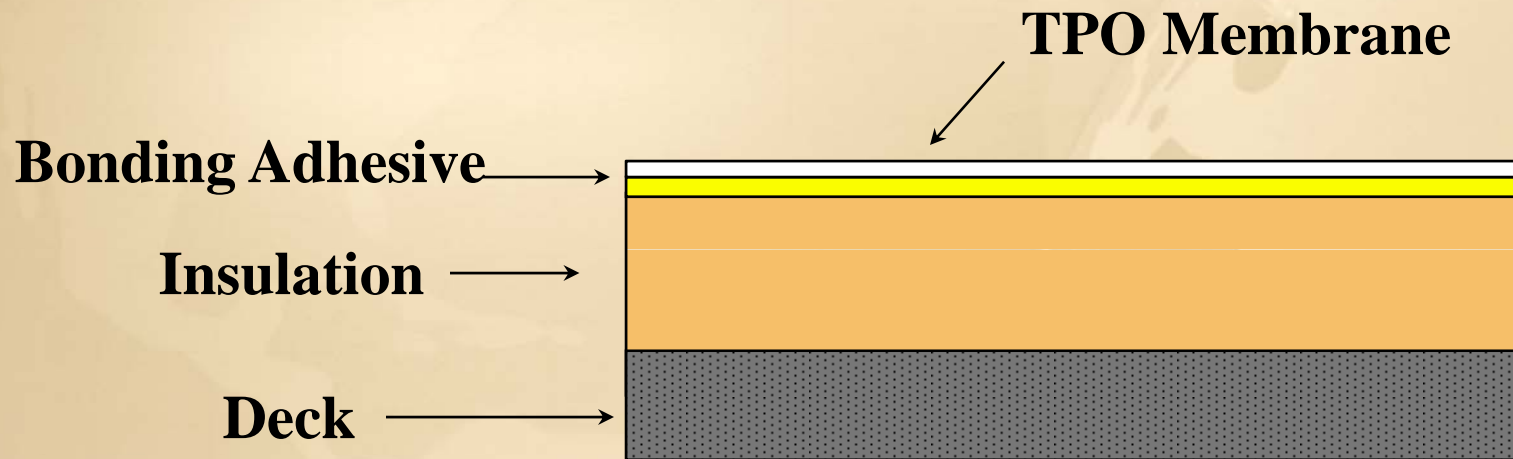

- System Design Adapts Easily To Unusual Roof Profiles or Slopes
- System Design Is Easy To "Beef Up" To Adapt To High Wind Conditions
- Exposed Roof Surface Is Easy To Inspect And Maintain
- Simple, Time-Proven Application Method Provides High Dependability



Ballasted System

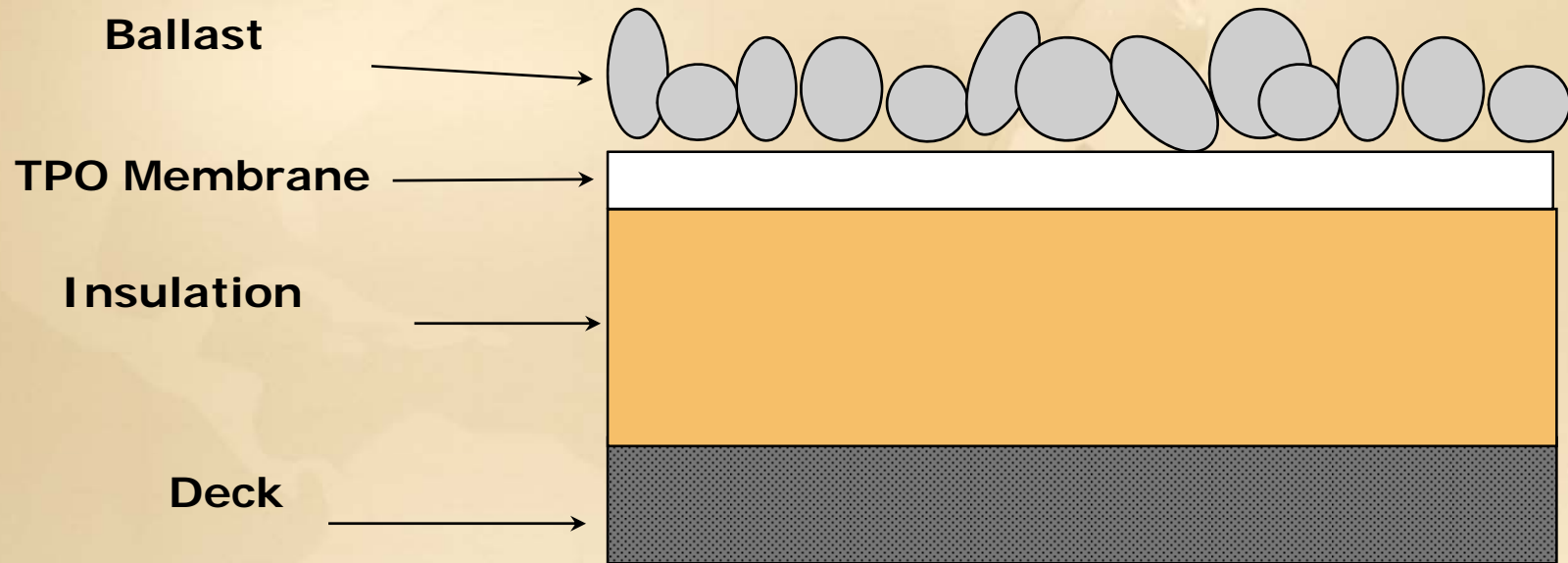

- Stone Ballast Provides Economical Class A Fire Rating
- Compatibility With Almost All Insulations Provides Design Flexibility
- Limited because of small panel sizes

Mechanically Attached System

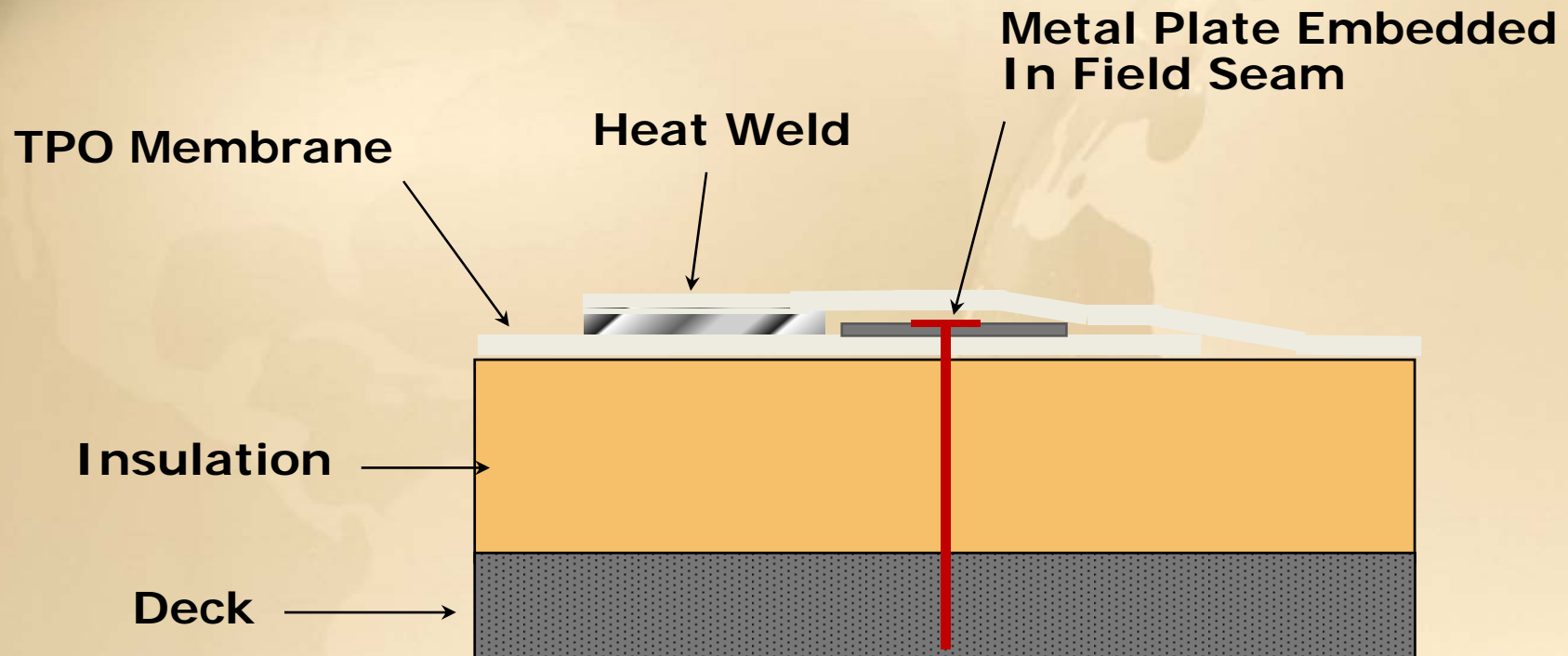

- Light Weight System - Adaptable To Almost All Roof Decks
- Small Panels Provide Fast, Efficient Coverage Of Small, Complicated Or Hard-To-Reach Roof Areas
- 10' Seam Spacing Provides Economical FM I-90 Rating





Base Tie-In

- Base Tie-Ins (BTI)
 - A **Required** Detail
 - Installed in 2 parts

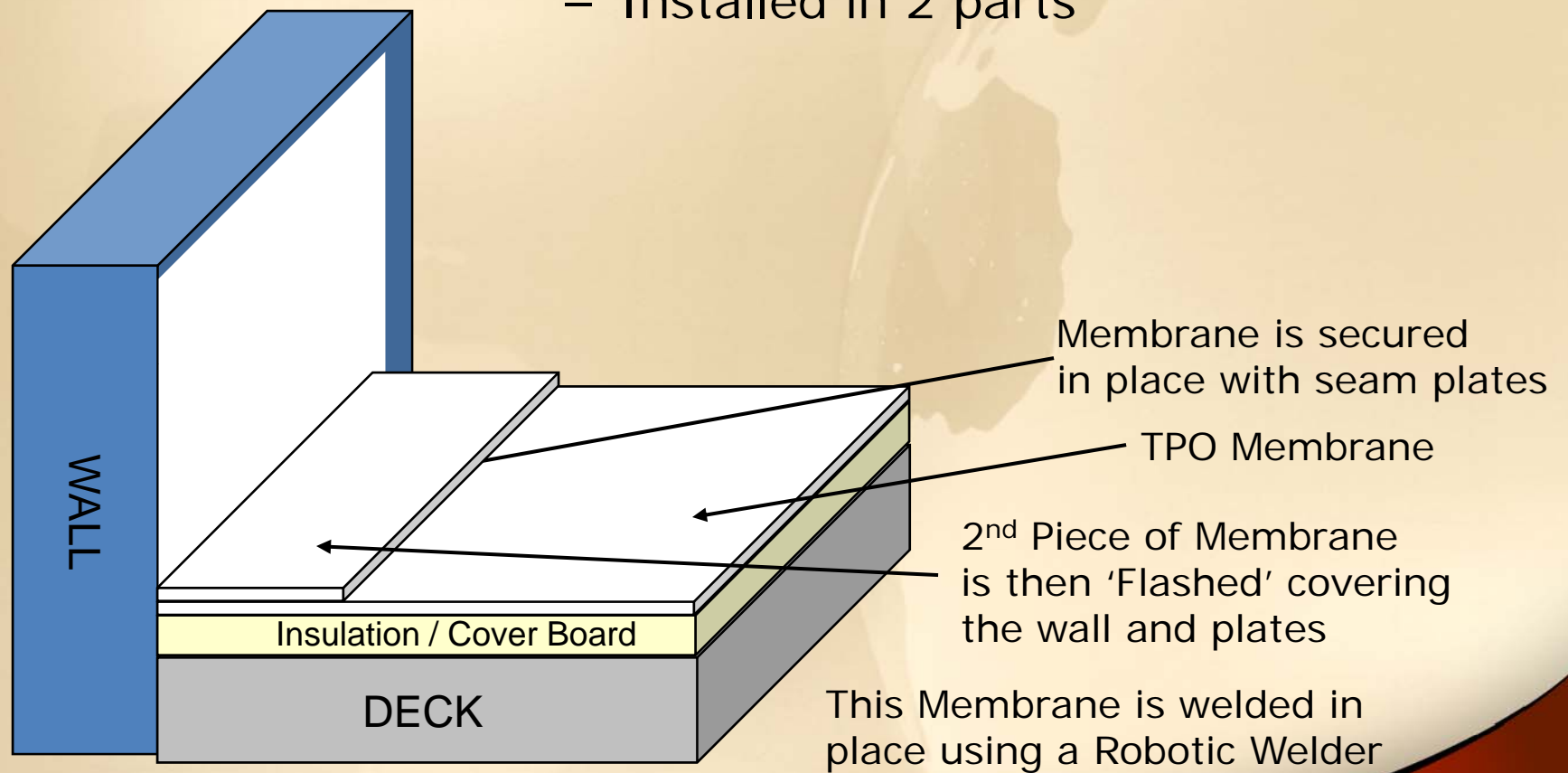



What's Wrong?





Installing a Pipe Boot:

- Base-Tie-Ins (BTI)
 - 20 Year option using TPO RPF
 - Installed exactly as an EPDM RPF

